

How to Specify a Spherical Vacuum Chamber

QUALITY | PRECISION | SERVICE



STEP 1: Specify the Material and Finish

MATERIAL OPTIONS:

- 304L Stainless Steel (standard)
- 316L Stainless Steel
- 6061 Aluminum

FINISH OPTIONS:

Sphere Finish Options:

- Mechanically Polished Brushed Finish (standard)
- Electropolished

Tubing Finish Options:

- Mechanically Polished Brushed Finish (standard)
- Electropolished

Flange Finish Options*

- Machined Finish (standard)
- Electropolished

*Sealing surfaces and knife edges are protected during any finishing process to ensure functionality.

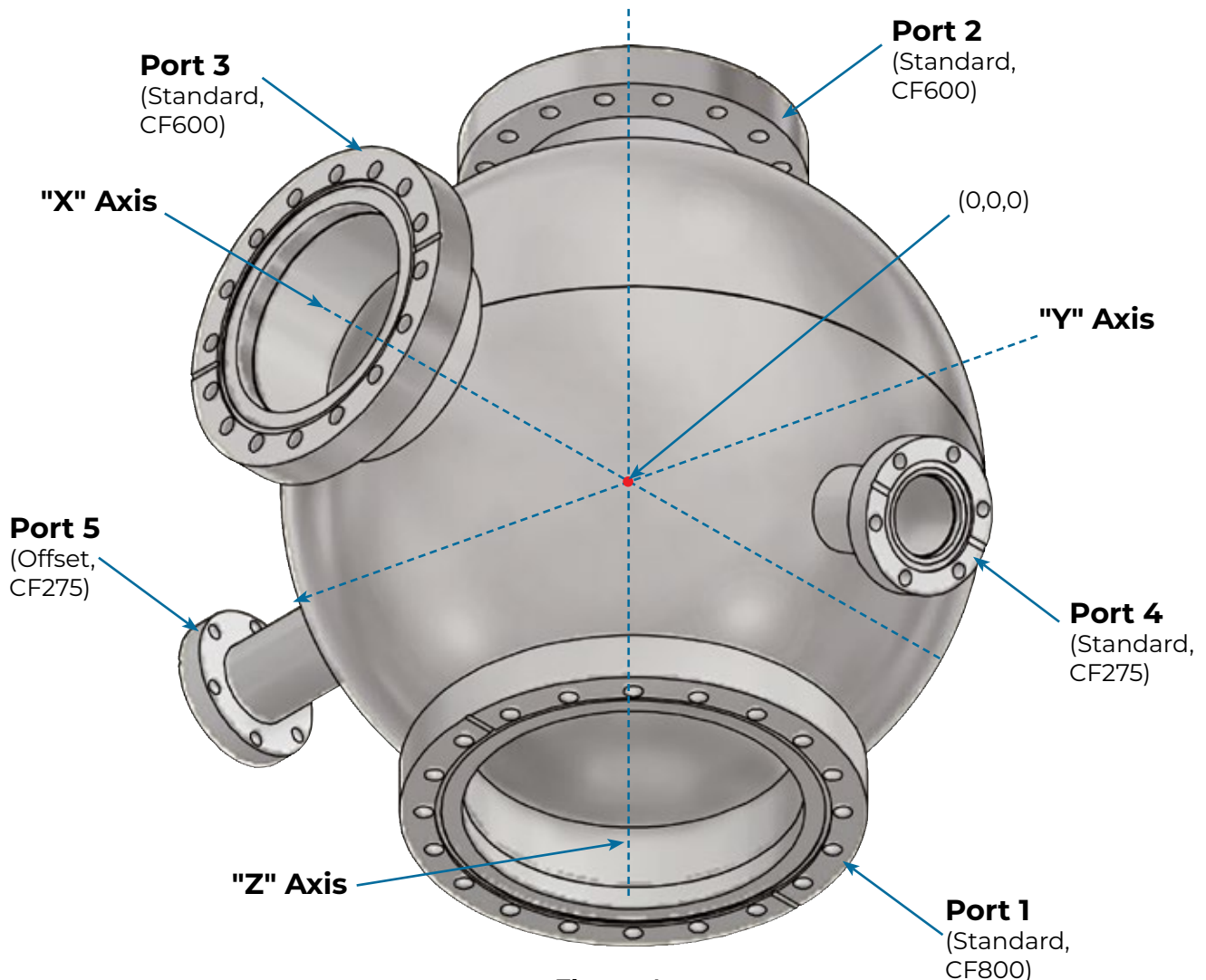

Figure 1:

Spherical Example Chamber with Port Numbers, Port Orientations, Flange Types & Sizes, and 3D Cartesian Coordinate System (Isometric)

STEP 2:
Specify the Main Body

The **Main Body** of a spherical chamber is defined as the sphere itself (excluding all ports). In most cases, including our **Spherical Example Chamber (Figure 1)**, this sphere is fabricated using two hemispheres (**Figure 2**).

Specify the Main Body Sphere

- Nominal Outer Diameter
- Nominal Wall Thickness

Portholes are the holes in a chamber body where tubing and flanges are eventually welded to make ports. When fabricating a sphere from two hemispheres, the first step is to machine the portholes that are located at the pole of each hemisphere. These portholes

allow access for welding, so ANCORP recommends that chamber designers:

- Locate your largest desired portholes at the poles of your spherical chamber.
- At minimum, locate at least one porthole that is 6-inches in diameter or larger at a pole.

If possible, additional portholes are machined into the hemispheres prior to welding.

Next, the two hemispheres are welded together along the interior of the seam where they meet to form a sphere. An interior weld is preferable to an exterior weld in accordance with good vacuum practice.

Finally, any remaining portholes are machined into the sphere (**Figure 3**).

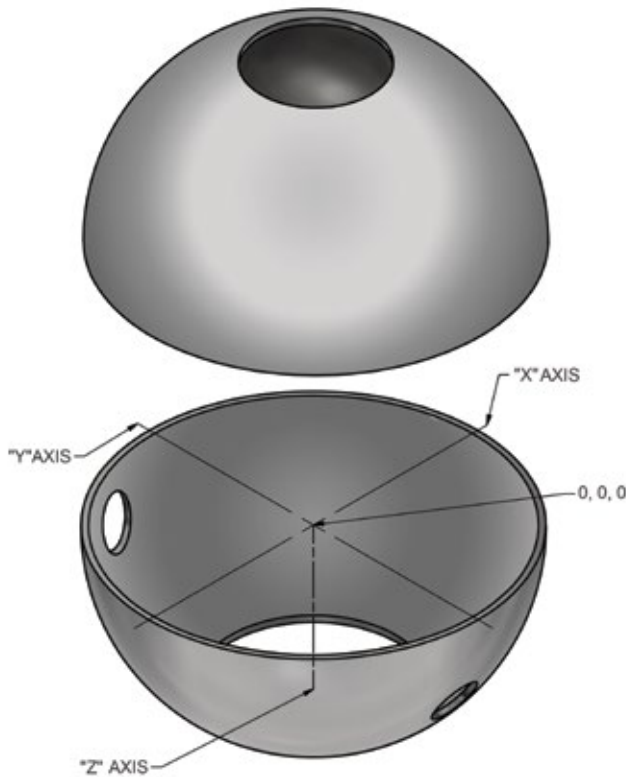

Figure 2:

Spherical Example Chamber - Upper and Lower Hemispheres Prior to Welding with 3D Cartesian Coordinate System (Isometric)

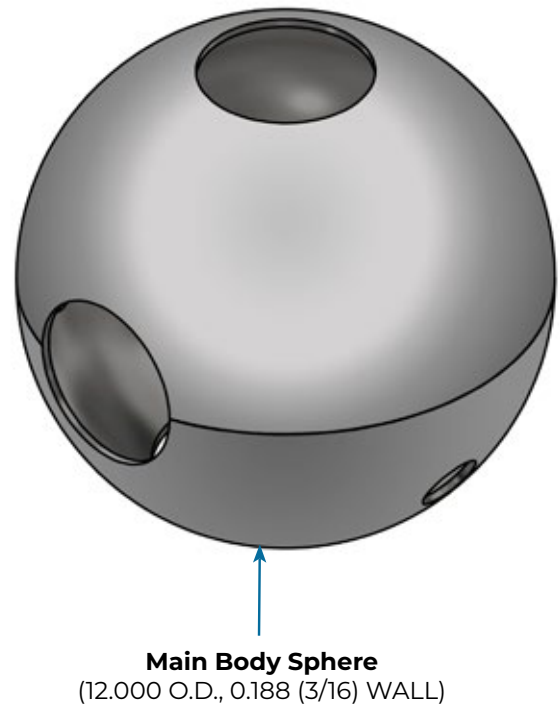

Figure 3:

Spherical Example Chamber - Main Body Sphere after Welding and Machining Remaining Portholes (Isometric)

STEP 3: Specify the Ports

The **Ports** of a spherical chamber are the tubulated, flanged points of access that allow vacuum hardware, instrumentation, and other components to connect to the chamber. On our **Spherical Example Chamber (Figure 1)**, we show five ports: **Ports 1, 2, 3, 4, & 5**.

A) SPECIFY PORT FLANGES* (Type & Size)

Please refer to the catalog for all possible flange sizes. Representative examples are provided in **Table 2** on page 6.

**Each flange size has an associated standard tube size. Unless otherwise requested, this standard tube size will be used.*

B) SPECIFY PORT LOCATION AND ORIENTATION

The following features and dimensions define a port's location and orientation on the spherical chamber (**Figures 4, 5, & 6**):

ORIENTATION: On a spherical chamber, we differentiate between two distinct port orientations: **Standard & Offset**.

- **Standard** (eg., Ports 1, 2, 3, 4)
 - o Focal Point is the center of the Main Body sphere
- **Offset** (eg., Port 5)
 - o Focal Point is not the center of the Main Body sphere

FOCAL POINT: A port's **Focal Point** is a feature that helps define the port's orientation and focal length.

- Locate each Focal Point in space using a 3-dimensional Cartesian coordinate system.

POLAR ANGLE: A port's **Polar Angle** defines its latitudinal position along the outer surface of the spherical chamber.

- Specify each port's Polar Angle relative to a common polar origin.

AZIMUTHAL ANGLE: A port's **Azimuthal Angle** defines its longitudinal position along the outer surface of the spherical chamber.

- Specify each port's Azimuthal Angle relative to a common azimuthal origin.

OFFSET DISTANCES: A port's **Offset Distances** define how far its Focal Point is from the center of the Main Body sphere.

Three Offset Distances are defined: one each along the X-Axis, Y-Axis, and Z-Axis of the Main Body sphere. Each Offset Distance is equal to the absolute value of the Focal Point coordinate along that same axis.

- Specify each port's Offset Distances.
 - o For Standard ports, the Offset Distances all equal zero.
 - o For Offset ports, at least one of the Offset Distances does not equal zero.

FOCAL LENGTH: A port's **Focal Length** defines the linear distance between the port's flange face and Focal Point.

- Specify each port's Focal Length relative to its flange face and its established Focal Point.

Table 1 on page 5 summarizes all the information needed to properly specify the ports on our **Spherical Example Chamber**.

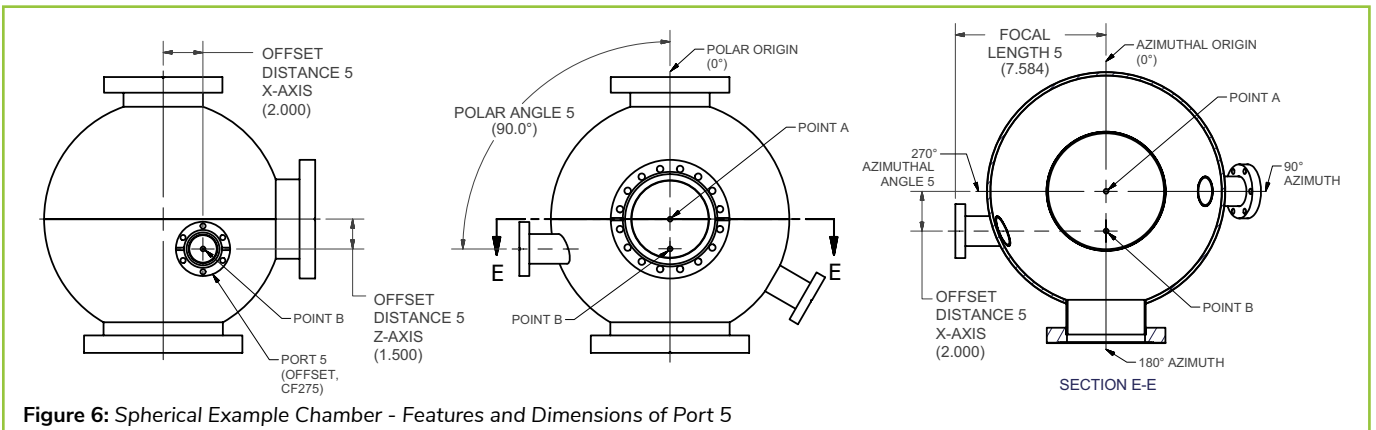
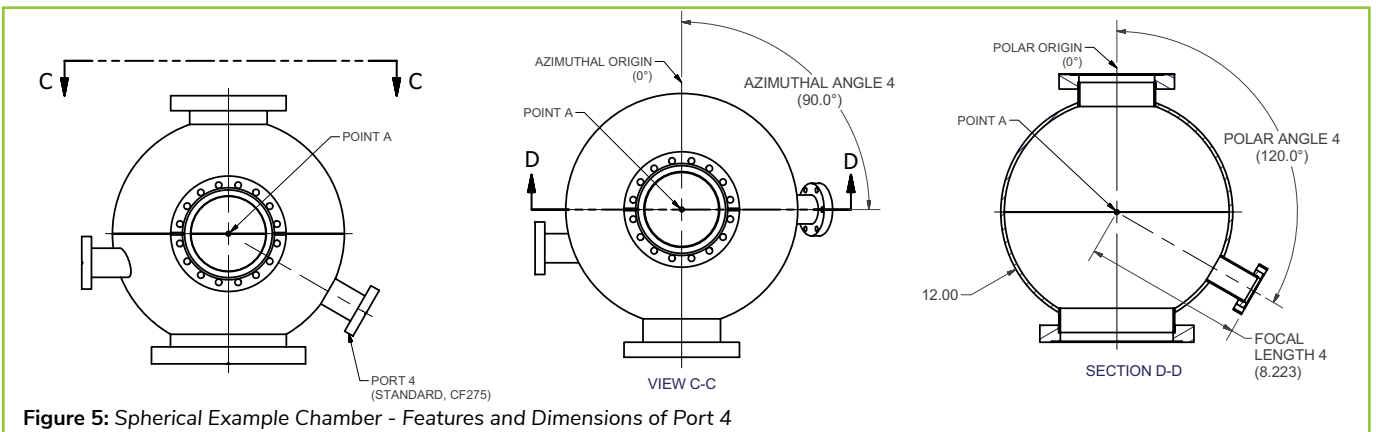
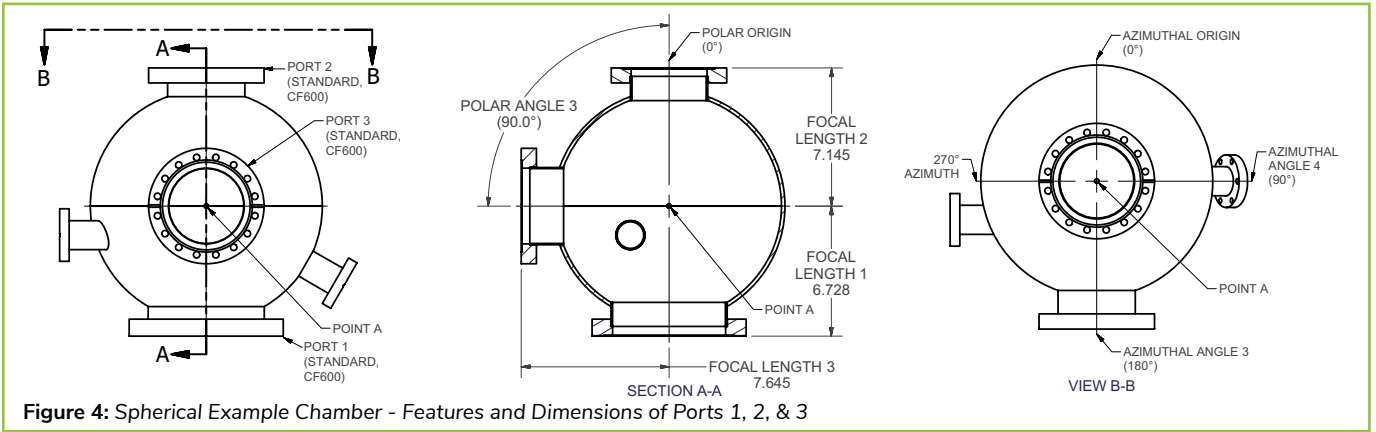

Table 1: Port Specifications for Spherical Example Chamber

Port	Flange	Orientation	Focal Pt.	Focal Point Coordinates (X,Y,Z)	Polar Angle	Azimuthal Angle	Offset Distances (X,Y,Z)	Focal Length
1	CF800	Standard	Point A	(0.000, 0.000, 0.000) in.	180.0°	0.0°	(0.000, 0.000, 0.000) in.	6.728 in.
2	CF600	Standard	Point A	(0.000, 0.000, 0.000) in.	0.0°	0.0°	(0.000, 0.000, 0.000) in.	7.145 in.
3	CF600	Standard	Point A	(0.000, 0.000, 0.000) in.	90.0°	180.0°	(0.000, 0.000, 0.000) in.	7.645 in.
4	CF275	Standard	Point A	(0.000, 0.000, 0.000) in.	120.0°	90.0°	(0.000, 0.000, 0.000) in.	8.223 in.
5	CF275	Offset	Point B	(2.000, 0.000, -1.500) in.	90.0°	270.0°	(2.000, 0.000, 1.500) in.	7.584 in.

Table 2: Flange Types, Sizes, Vacuum Ratings, and Temperature Ratings

FLANGE TYPE	FLANGE SIZES	VACUUM RATING	TEMPERATURE RANGE
CF - Conflat	133, 212, 275, 338, 450, 462, 600, 675, 800, 1000, 1200, 1325, 1400, 1450, 1650	1X10 ⁻¹³ Torr	-200°C to 450°C
WF - Wire-Sealed	1200, 1400, 1700, 1900, 2200, 2700	1X10 ⁻¹³ Torr	-200°C to 450°C
QF - Quick Flange	10, 16, 25, 40, 50, 63, 80, 100, 160, 200	1X10 ⁻⁸ Torr	-50°C to 200°C
LF - Large Flange (Clamp)	63, 80, 100, 160, 200, 250, 320, 400, 500	1X10 ⁻⁸ Torr	-50°C to 200°C
LFB - Large Flange (Bolt)	63, 80, 100, 150, 200, 250, 320, 400, 500	1X10 ⁻⁸ Torr	-50°C to 200°C
ASA	100, 150, 200, 300, 400, 600, 800, 1000	1X10 ⁻⁸ Torr	-20°C to 200°C

ANCORP's 5-Axis YB Machine is ready for your next project.



Our Product Lines



**ISO QF/LF
Flanges and Fittings**



**CF and Wire Seal
Flanges and Fittings**



ASA Flanges & Fittings



Hybrid Adapters



Vacuum Valves



Vacuum Feedthroughs



Traps and Filters



**Flexible Metal Hose
and Bellows**



**Quick Disconnect
Fittings**



Weldable Components



**Glass Components &
Chamber Accessories**



**Custom Fabrication &
Chambers**

Order online at www.ancorp.com

HEAT TREATING | CRYOGENICS | NANOTECHNOLOGY | SEMICONDUCTOR | THIN FILM | PARTICLE PHYSICS | MOCVD



CUSTOM SHAPE

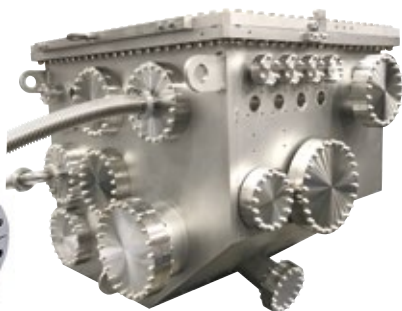

BOX



CYLINDRICAL



SPHERICAL

Visit us at www.ancorp.com to order
High Vacuum Components Online



ANCORP
1-800-FLANGE1
www.ancorp.com

Proud to be a
U.S. Manufacturer