

UHV BURST DISK

YOUR FIRST LINE OF DEFENSE AGAINST
ACCIDENTAL PRESSURIZATION



ANCORP  **MADE IN USA**

Vacuum systems are normally rated for an external load of one atmosphere and should not be exposed to excess positive pressure. For this reason, **ANCORP** has designed a new line of UHV burst disks for our customers who require protection from accidental over-pressurization of their vacuum systems.

ANCORP offers burst disks with CF133 or CF275 metal seal flange connections. Gas recovery port connections are available in CF338 or QF50 flanges. The burst disks feature all-metal stainless steel construction for UHV applications and are scored to prevent fragmenting upon rupture, thus protecting personnel and equipment from harm. However, once the disk has ruptured it is no longer usable and must be replaced.

The low pressure burst disk is ISO 4126-2 compliant, while the ASME burst disk is ASME UD certified and 10CFR851 compliant. Burst disks are constructed with a frustum metal membrane which is capable of sustaining a vacuum load. The low pressure burst disk will activate if the pressure inside a vacuum system reaches 5 PSIG, the ASME overpressure burst disk will activate at 11.5 PSIG, and the high-pressure burst disk will activate at 25 PSIG.

Features

- Stainless steel body and disk membrane
- Bakeable to 450°C
- Protects sensitive components from accidental over-pressurization
- Protects personnel from harmful ruptures
- Protects equipment from costly damage and down-time
- Optional gas recovery system to prevent gases escaping into the atmosphere
- Compact design with no moving parts
- ASME UD Certified to be 10CFR851 compliant
- Low pressure burst disk designed to be ISO 4126-2 compliant
- CF133 or CF275 metal seal flange connections (CF338 or QF50 for gas recovery ports)
- The scored membrane prevents fragmentation upon rupture.

Low Pressure Burst Disk (5-7 psig)



Our low pressure burst disks are designed with a frustum metal membrane which is able to sustain a vacuum load and are ISO 4126-2 compliant. The disk membrane will activate and fully open when a pressure differential between 5 and 7 PSIG is reached. In scenarios where gas back-fill could be dangerous, the optional gas recovery port can be connected to your gas line using a CF338 or QF50 flange.

Specifications

- Pressure relief range: 5 to 7 PSIG
- UHV Compatible all-metal construction
- Bakeable to 450°C
- 1.33" or 2.75" ConFlat flange mounting
- Gas recovery port options available with QF50 or CF338 flange connection
- ISO 4126-2 compliant
- Leak tight to 2×10^{-10} std. cc/sec of Helium
- Calculated Flow rates:
107 SCFM on 1.33" flange assembly
435 SCFM on 2.75" flange assembly

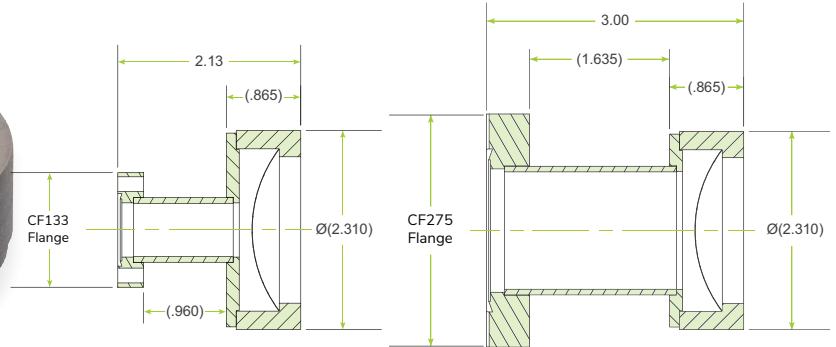

BD-LP-CF133
Low Pressure Burst Disk with CF133 Flange

BD-LP-CF275
Low Pressure Burst Disk with CF275 Flange

PART ID	REFERENCE NUMBER	DESCRIPTION	UNIT PRICE
9100032	BD-LP-CF133	Low Pressure Burst Disk, CF133 Flange	\$595
9100033	BD-LP-CF275	Low Pressure Burst Disk, CF275 Flange	\$625

Low Pressure Burst Disk (5-7 psig) with Optional Gas Recovery Port

CONFLAT
Gas Recovery Port

BD-LP-CF133XCF338-GRP
Low Pressure Burst Disk with CF133 Flange and CF338 Gas Recovery Port

BD-LP-CF275XCF338-GRP
Low Pressure Burst Disk with CF275 Flange and CF338 Gas Recovery Port

QF (KF)
Gas Recovery Port

BD-LP-CF133XQF50-GRP
Low Pressure Burst Disk with CF133 Flange and QF50 Gas Recovery Port

BD-LP-CF275XQF50-GRP
Low Pressure Burst Disk with CF275 Flange and QF50 Gas Recovery Port

PART ID	REFERENCE NUMBER	DESCRIPTION	UNIT PRICE
9100038	BD-LP-CF133XCF338-GRP	Low Pressure Burst Disk, CF133 Flange with CF338 Gas Recovery Port	\$695
9100039	BD-LP-CF133XQF50-GRP	Low Pressure Burst Disk, CF133 Flange with QF50 Gas Recovery Port	\$695
9100040	BD-LP-CF275XCF338-GRP	Low Pressure Burst Disk, CF275 Flange with CF338 Gas Recovery Port	\$725
9100041	BD-LP-CF275XQF50-GRP	Low Pressure Burst Disk, CF275 Flange with QF50 Gas Recovery Port	\$725



Our ASME UD certified burst disks are designed for systems that require pressure relief above atmospheric pressure. The disk membrane will activate and fully open when a pressure differential between 9 and 11.5 PSIG is reached. The optional gas recovery port can be connected to your gas line using a CF338 or QF50 flange.

Specifications

- Pressure relief range: 9 to 11.5 PSIG
- UHV Compatible all-metal construction
- Bakeable to 450°C
- 1.33" or 2.75" ConFlat flange mounting
- Gas recovery port options available with QF50 or CF338 flange connection
- ASME UD certified 10CFR851 compliant
- Leak tight to 2 x 10⁻¹⁰ std. cc/sec of Helium
- Calculated Flow rates
107 SCFM on 1.33" flange assembly
435 SCFM on 2.75" flange assembly

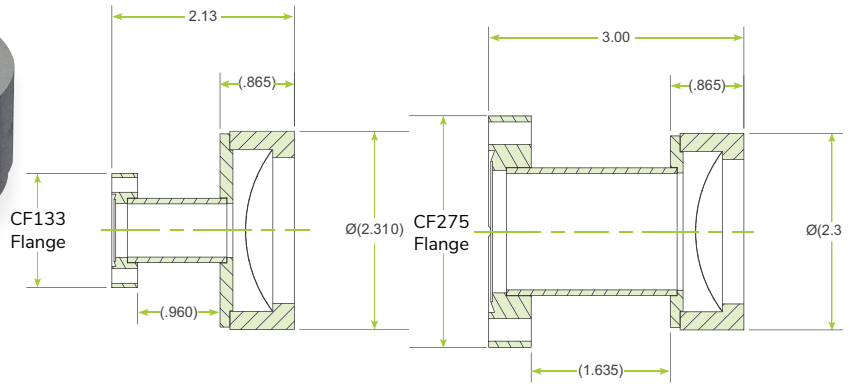

BD-ASME-CF133
ASME Burst Disk with CF133 Flange

BD-ASME-CF275
ASME Burst Disk with CF275 Flange

PART ID	REFERENCE NUMBER	DESCRIPTION	UNIT PRICE
9100030	BD-ASME-CF133	ASME Burst Disk, CF133 Flange	\$595
9100031	BD-ASME-CF275	ASME Burst Disk, CF275 Flange	\$625

ASME UD Certified (9-11.5 psig) with Optional Gas Recovery Port

CONFLAT
Gas Recovery Port

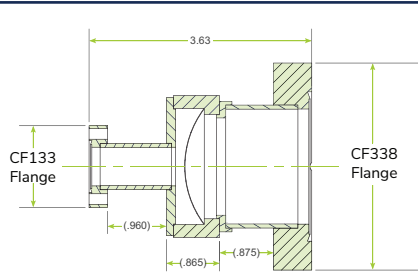
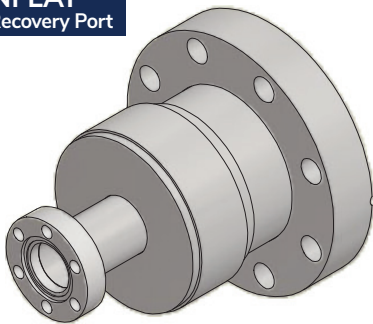

BD-ASME-CF133XCF338-GRP
-ASME-Burst Disk with CF133 Flange-
and CF338 Gas Recovery Port

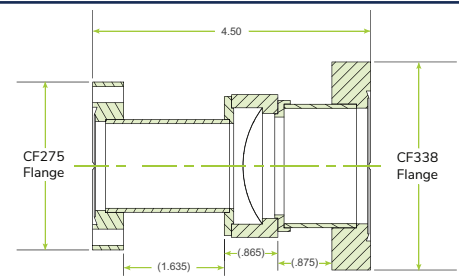

BD-ASME-CF275XCF338-GRP
ASME Burst Disk with CF275 Flange
and CF338 Gas Recovery Port

QF (KF)
Gas Recovery Port

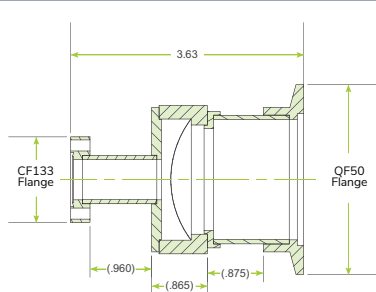
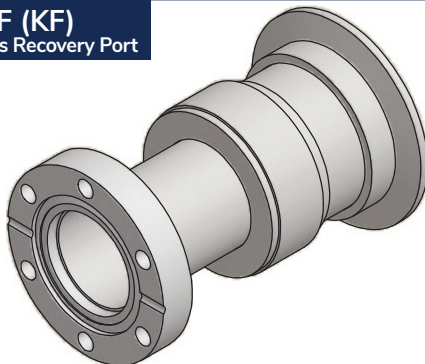

BD-ASME-CF133XQF50-GRP
ASME Burst Disk with CF133 Flange
and QF50 Gas Recovery Port

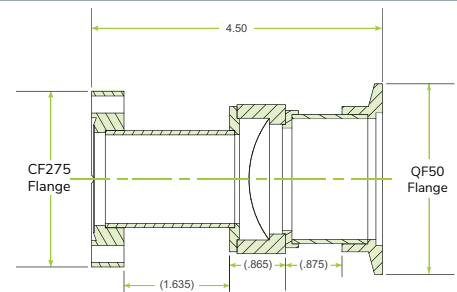

BD-ASME-CF275XQF50-GRP
ASME Burst Disk with CF275 Flange
and QF50 Gas Recovery Port

PART ID	REFERENCE NUMBER	DESCRIPTION	UNIT PRICE
9100034	BD-ASME-CF133XCF338-GRP	ASME Burst Disk, CF133 Flange with CF338 Gas Recovery Port	\$695
9100035	BD-ASME-CF133XQF50-GRP	ASME Burst Disk, CF133 Flange with QF50 Gas Recovery Port	\$695
9100036	BD-ASME-CF275XCF338-GRP	ASME Burst Disk, CF275 Flange with CF338 Gas Recovery Port	\$725
9100037	BD-ASME-CF275XQF50-GRP	ASME Burst Disk, CF275 Flange with QF50 Gas Recovery Port	\$725

High Pressure Burst Disk (25 psig)



Our high pressure burst disks are designed with a frustum metal membrane which is able to sustain a vacuum load. The disk membrane will activate and fully open when pressure reaches 25 PSIG.

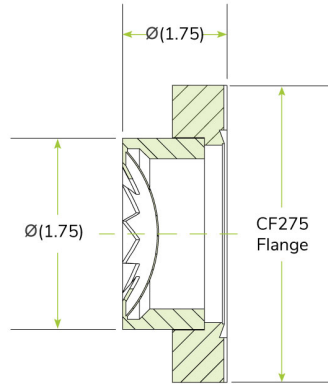

BD-25PSIG-CF275
High Pressure Burst Disk with CF275 Flange

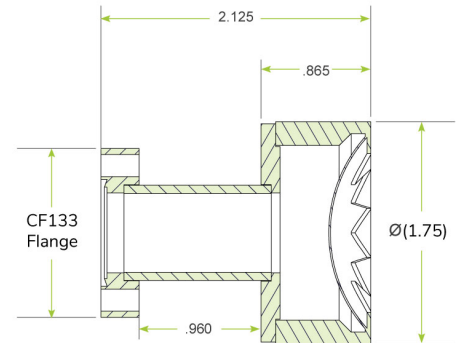

BD-25PSIG-CF133
High Pressure Burst Disk with CF133 Flange

Specifications

- Pressure relief at 25 PSIG
- UHV Compatible all-metal construction
- Temperature range: -200°C to +350°C
- 1.33" or 2.75" ConFlat flange mounting
- Leak tight to 2×10^{-10} std. cc/sec of Helium
- Vacuum Rated:
 - Elastomer Seals 1×10^{-8}
 - Copper Seals 1×10^{-13}

PART ID	REFERENCE NUMBER	DESCRIPTION	UNIT PRICE
9100042	BD-05025PSIG-CF275	High Pressure Burst Disk, CF275 Flange	\$250
9100043	BD-05025PSIG-CF133	High Pressure Burst Disk, CF133 Flange	\$250

UHV BURST DISK

**YOUR FIRST LINE
OF DEFENSE AGAINST**

**ACCIDENTAL
PRESSURIZATION**



Visit us at www.ancorp.com to order
High Vacuum Components Online



ANCORP

1-800-FLANGE1
www.ancorp.com

Proud to be a
U.S. Manufacturer